



## HD 52.3D... 2 AXES ULTRASONIC ANEMOMETER

### 2 axes ultrasonic Anemometers series HD 52.3D....

The instruments of the series HD52.3D... are 2 axes ultrasonic static anemometers for measuring:

- Wind speed and direction, U-V Cartesian components of wind speed,
- Relative Humidity and Temperature (**option, code "17"**),
- Diffuse Solar Radiation (**option, code "P"**),
- Barometric pressure (**option, code "4"**).

All models are equipped with compass.

RS232, RS485 and SDI-12 serial interfaces are available with **NMEA**, **MODBUS-RTU** and **SDI-12** communication protocols.

All versions have two analogical outputs, both for wind speed and for direction, factory configurable among 4÷20mA (**standard**), 0÷1V, 0÷5V, 0÷10V (**to be specified when ordering**).

The **heater** option prevents the accumulation of snow and ice from forming, allowing accurate measurements in all environmental conditions.

Optionally available, **ILAC-MRA (ACCREDIA)** traceable factory calibration.

### Advantages:

- The absence of moving parts minimizes maintenance;
- High sensitivity for detecting very low speeds, which are not detectable by traditional methods;
- The low power of the instrument allows installation in remote sites, with power from solar panel and battery;
- The heating option "**R**" prevents the accumulation of snow and ice from forming, allowing accurate measurements in all environmental conditions;
- Fast and easy installation (on 40mm diameter pole, optional installation kit HD2004.20), alignment facilitated by built-in compass;
- The available measurement options join together in one single, compact and light-weight instrument, the main variables of interest in weather stations;
- MODBUS RTU output allows instrument networking.

### Typical applications:

- Weather stations
- Environmental monitoring
- Agriculture
- Sports
- Marine and Harbour applications
- Airports
- HVAC
- Construction/Crane safety
- Renewable energy
- Building automation

### Technical specifications:

Wind speed	
Employed sensor type	Ultrasonic
Measuring Range	0...60 m/s
Resolution	0.01 m/s
Accuracy	Whichever is greater $\pm 0,3$ m/s or $\pm 2\%$ , (0...35 m/s) $\pm 3\%$ (> 35 m/s)
Wind direction	
Employed sensor type	Ultrasonic
Measuring Range	0...360°
Resolution	0.1°
Accuracy	$\pm 2^\circ$ RMSE from 1.0 m/s
Compass	
Employed sensor type	Magnetic
Measuring Range	0...360°
Resolution	0.1°
Accuracy	$\pm 1^\circ$
Air temperature (option 17 is requested)	
Employed sensor type	Pt100
Measuring Range	-40...+60 °C
Resolution	0.1 °C
Accuracy	$\pm 0,15^\circ\text{C} \pm 0,1\%$ of the measure
Relative Humidity (option 17 is requested)	
Employed sensor type	Capacitive
Measuring Range	0...100%RH
Resolution	0.1%
Accuracy (@ T = 15...35 °C)	$\pm 1,5\%$ UR (0..90%RH), $\pm 2\%$ RH (remaining field)
Accuracy (@ T = -40...+60 °C)	$\pm (1,5 + 1,5\%$ of the measure)%RH
Barometric Pressure (option 4 is requested)	
Principle	Piezoresistive
Measuring Range	600...1100 hPa
Resolution	0.1 hPa
Accuracy	$\pm 0,5$ hPa @ 20°C
Solar Radiation (option P is requested)	
Employed sensor type	Thermopile
Measuring Range	0...2000 W/m <sup>2</sup>
Resolution	1 W/m <sup>2</sup>
Accuracy	2 <sup>nd</sup> class Pyranometer
General features	
Power supply	10...30 Vdc
Power Consumption	26mA @ 12Vdc without heater, 6W with heater
Serial Outputs	RS232, RS485, RS422 and SDI-12
Communication Protocols	NMEA, MODBUS-RTU, SDI-12
Analog Outputs	2 analog outputs for wind speed and direction. Output type to be specified when ordering among 4...20mA ( <b>standard</b> ), 0...1V, 0...5V and 0...10V ( <b>option 0...10V requires power supply 15...30Vdc</b> )
Electrical connection	male connector M23 19 poles
Working temperature	-40...+60 °C
Dimensions	H=179mm, Ø=150mm (HD52.3D, HD52.3D4) H=200mm, Ø=150mm (HD52.3DP, HD52.3DP4) H=336mm, Ø=150mm (HD52.3D17, HD52.3D147) H=357mm, Ø=150mm (HD52.3DP17, HD52.3DP147)
Weight	about 1 Kg (full version, HD52.3DP147)
Housing	Plastic material: LURAN®S (ASA) Metallic parts made of AISI 316
Protection degree	IP66

**DIMENSIONS (mm)**

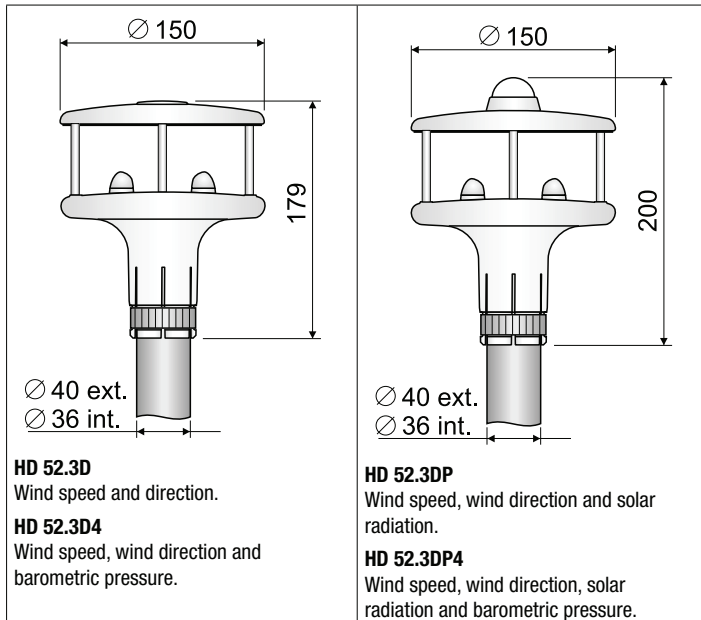

**HD 52.3D**  
Wind speed and direction.  
**HD 52.3D4**  
Wind speed, wind direction and barometric pressure.

**HD 52.3DP**  
Wind speed, wind direction and solar radiation.  
**HD 52.3DP4**  
Wind speed, wind direction, solar radiation and barometric pressure.

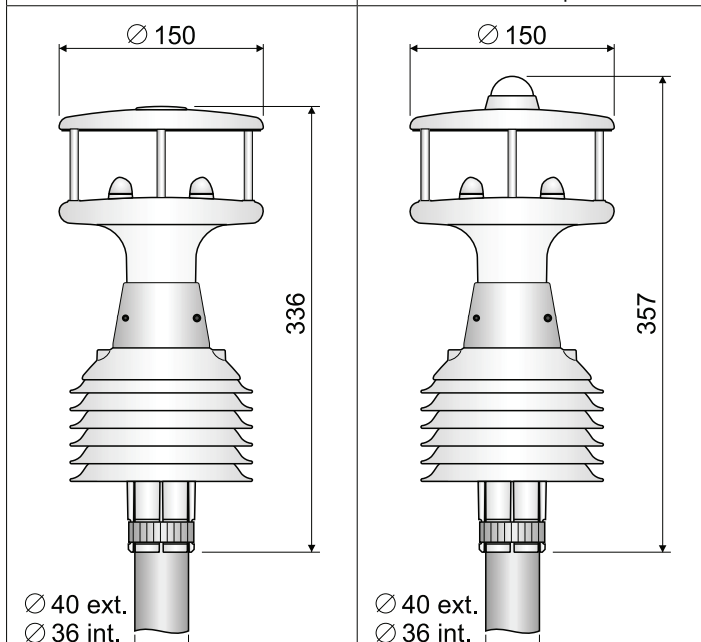

**HD 52.3D17**  
Wind speed, wind direction, temperature and relative humidity.  
**HD 52.3D147**  
Wind speed, wind direction, temperature, relative humidity and barometric pressure.

**HD 52.3DP17**  
Wind speed and direction, solar radiation, temperature, relative humidity.  
**HD 52.3DP147**  
Wind speed, wind direction, solar radiation, temperature, relative humidity and barometric pressure.

**PURCHASING CODES**

**HD 52.3D**

**R** = heater option  
**Blank** = not heated

**P** = solar radiation option (pyranometer)  
**4** = barometric pressure option  
**17** = relative humidity and temperature option  
**P4** = solar radiation and barometric pressure option  
**P17** = solar radiation, relative humidity and temperature option  
**147** = barometric pressure, relative humidity and temperature option  
**P147** = solar radiation, barometric pressure, relative humidity and temperature option  
**No characters** = basic version: wind speed and direction

Analog outputs for wind speed and direction: 4...20mA standard; to be requested: 0...1V, 0...5V or 0...10V (0...10V option requires power 15...30Vdc).

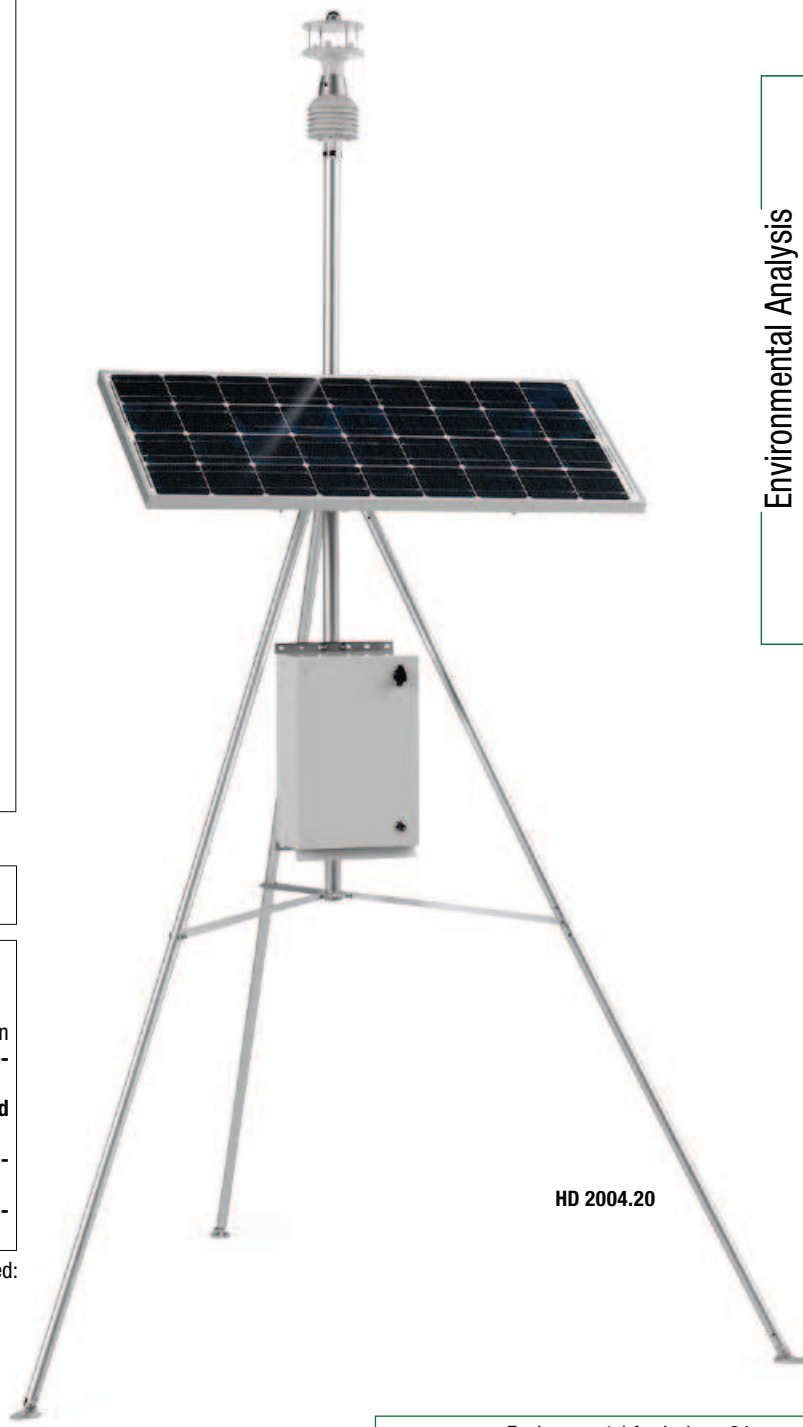
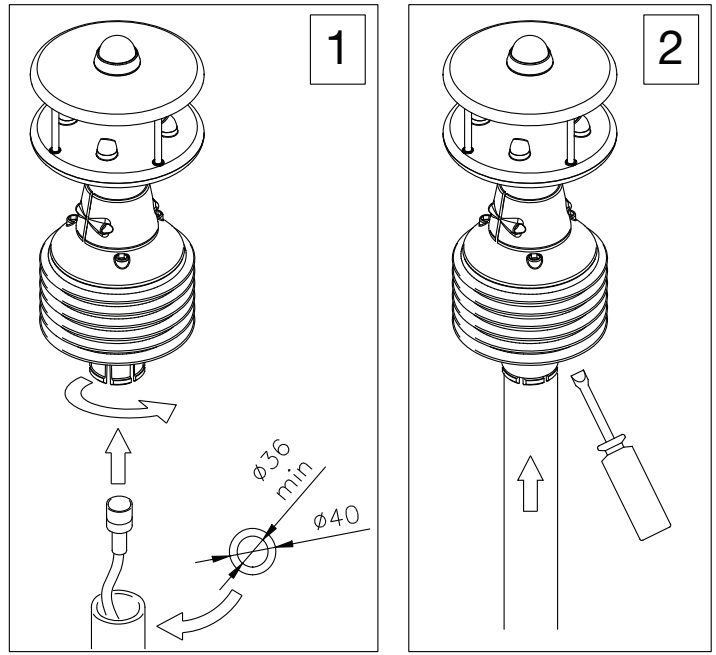

**HD 2004.20**

Environmental Analysis

**HD52.3D...**: 2 axes ultrasonic static anemometers for the measure of wind speed and direction, U-V Cartesian components of wind speed, relative humidity and temperature (**optional**), diffuse solar radiation (**optional**) and barometric pressure (**optional**). A compass is supplied. RS232, RS485 and SDI-12 serial outputs, **NMEA**, **MODBUS-RTU** and **SDI-12** communication protocols. Two analogical outputs, for wind speed and direction, factory among 4÷20mA (**standard**), 0÷1V, 0÷5V or 0÷10V (**to be specified when ordering**). **Heater option** is available. Power supply: 10...30Vdc (15...30Vdc for 0÷10V analog outputs). Installation on a pole: external Ø40mm and internal Ø36mm. Input with M2319-pin male connector and M23 19-pin steering female connector. **Optional 5m or 10m cable with a connector on one side and open wires on the other.**

#### ACCESSORIES

**CP52.5:** Connection cable with M23 19-pin steering female connector on one side, free wires on the other. 5m long.

**CP52.10:** Connection cable with M23 19-pin steering female connector on one side, free wires on the other. 10m long.

**CP52.C:** Further M23 19-pin steering female connector.

**HD2004.20:** Tripod kit for installing anemometers on a flat base. Height 3m.

**HD2004.22:** 1200x530x34mm Solar panel mounting kit to a Ø40÷50mm pole. AISI 304 stainless steel.

**HD2004.30:** 80W monocrystalline solar panel. Dimensions 1200 x 530 x 34 mm. Model MD5000080 – CS EVOLUTION.

**HD32.35:** Outdoor housing complete with acquisition system for weather stations.

**Material: AISI 304 stainless steel.** Screen to protect the housing from solar radiation. Powder-coated white. Double locking one of which is a key. Dimensions 450 x 300 x 210 mm. Degree of protection IP66. Supplied with accessories for attachment to the pole diameter 36 ÷ 52 mm. Provided for 100 ÷ 240Vac mains power supply, includes: HD32MT.1 datalogger, AC/DC power supply unit with integrated battery charger, 12V rechargeable backup battery, surge protectors, disconnectors, terminal block for power supply distribution and connectors for connecting the external sensors. **Wired and tested.**

**HD32.35FP:** Outdoor housing complete with acquisition system for weather stations.

**Material: AISI 304 stainless steel.** Screen to protect the housing from solar radiation. Powder-coated white. Double locking one of which is a key. Dimensions 450 x 300 x 210 mm. Degree of protection IP66. Supplied with accessories for attachment to the pole diameter 36 ÷ 52 mm. Provided for power supply from solar panel, includes: HD32MT.1 datalogger, solar charge controller, terminal block for power supply distribution and connectors for connecting the external sensors. **Wired and tested.**

**HD32.36:** Outdoor housing complete with acquisition system for weather stations.

**Material: Polyester with fiberglass-reinforced hot-pressed.** Screen to protect the housing from solar radiation, powder-coated anodized aluminum. White. Key lock. Dimensions 415 x 310 x 170 mm. Degree of protection IP66. Supplied with accessories for attachment to the stainless steel pole diameter 36 ÷ 52 mm. Provided for 100 ÷ 240Vac mains power supply, includes: HD32MT.1 datalogger, AC/DC power supply unit with integrated battery charger, 12V rechargeable backup battery, surge protectors, disconnectors, terminal block for power supply distribution and connectors for connecting the external sensors. **Wired and tested.**

**HD32.36FP:** Outdoor housing complete with acquisition system for weather stations.

**Material: Polyester with fiberglass-reinforced hot-pressed.** Screen to protect the housing from solar radiation, powder-coated anodized aluminum. White. Key lock. Dimensions 415 x 310 x 170 mm. Degree of protection IP66. Supplied with accessories for attachment to the stainless steel pole diameter 36 ÷ 52 mm. Provided for power supply from solar panel, includes: HD32MT.1 datalogger, solar charge controller, terminal block for power supply distribution and connectors for connecting the external sensors. **Wired and tested.**

